

## LH12019/12020/12029 智能家居传感器

特点与用途:

单点式平行梁称重传感器，用于电子秤、厨房秤、手提秤、电子天平及工业称重系统

Features & Applications :

Single-ended, aluminum load cell, simple structure. Suitable for electronic scale, balance, kitchen scale and industrial weighing system.

量程/Capacity: 5-50kg

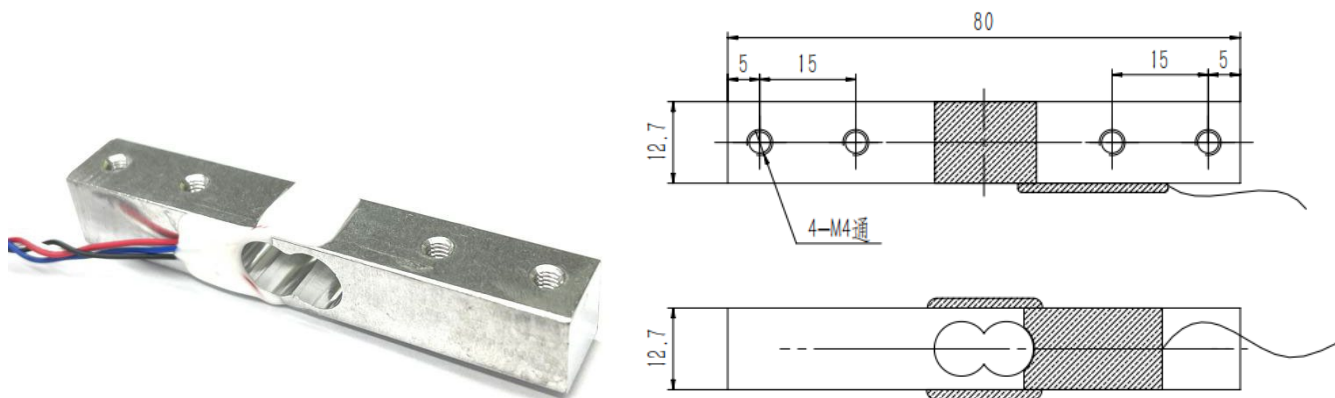

\*可根据客户实际需求定制外形与量程\*

技术参数 (Specification)			
输出灵敏度 Rated Output	1.0±0.1 mV/V	材质 Material	铝合金/Al. alloy
零点输出 Zero balance	±0.1 mV/V	绝缘电阻 Insulation resistance	≥5GΩ/100VDC
非线性 Non-linearity	±0.05%FS	最大激励电压 Max. excitation	10V DC
滞后 Hysteresis	±0.05%FS	使用温度 Operating temperature	-20 ~ +60°C
重复性 Repeatability	±0.05%FS	存储温度 Storage temperature	-20 ~ +80°C
蠕变(1分钟) Creep (1min.)	±0.05%FS	安全载荷 Safe overload	150%FS
灵敏度温度漂移 Temp effect on output	±0.1%FS/10°C	极限载荷 Ultimate overload	200%FS
零点温度漂移 Temp effect on zero	±0.3%FS/10°C	防护等级 Protection Class	IP65
输入电阻 Input Impedance	1000±20	输出电阻 Output impedance	1000±20
电缆连接方式 Cable color Code		Ex + : 红 Red Sig. + : 蓝 Blue	Ex - : 黑 Black Sig. - : 白 White