

LH12023 吊瓶输液器传感器

特点与用途:

单点铝合金平行梁力敏传感器, 结构简单, 适用于智慧医疗, 智能家具, 智能家电, 人工智能等行业。

Features & Applications :

Single-ended, aluminum load cell, simple structure, suitable for industries such as smart healthcare, smart furniture, smart home appliances, artificial intelligence, etc.

量程/Capacity : 0.5,1,3,5,10kg

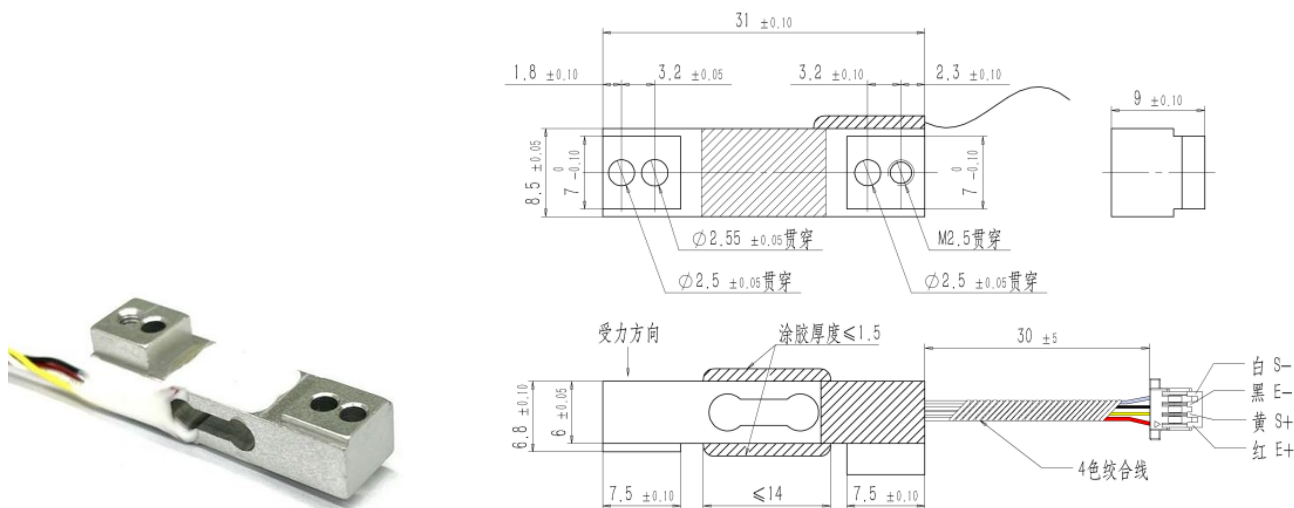

可根据客户实际需求定制外形与量程

| 技术参数 (Specification) | | | |
|----------------------------------|---|-------------------------------|---------------|
| 输出灵敏度 Rated Output | 1.0±0.2 mV/V | 材质 Material | 铝合金/Al. alloy |
| 零点输出 Zero balance | ±0.2 mV/V | 绝缘电阻 Insulation resistance | ≥5GΩ/100VDC |
| 非线性 Non-linearity | ±0.05%FS | 最大激励电压 Max. excitation | 10V DC |
| 滞后 Hysteresis | ±0.05%FS | 使用温度 Operating temperature | -20 ~ +60°C |
| 重复性 Repeatability | ±0.05%FS | 存储温度 Storage temperature | -20 ~ +80°C |
| 蠕变(3分钟) Creep (3min.) | ±0.15%FS | 安全载荷 Safe overload | 150%FS |
| 灵敏度温度漂移 Temp effect on output | ±0.5%FS/10°C | 极限载荷 Ultimate overload | 200%FS |
| 零点温度漂移 Temp effect on zero | ±0.5%FS/10°C | 防护等级 Protection Class | IP65 |
| 输入电阻 Input Impedance | 1000±20 | 输出电阻 Output impedance | 1000±20 |
| 电缆连接方式 Cable color Code | Ex + : 红 Red Ex - : 黑 Black - Sig. + : 黄 Yellow Sig. - : 白 White - | | |