

# LH129

**特点和用途:**

拉式合金钢制称重传感器。  
用于吊钩秤、料斗秤、工业称重系统。

**Features & Applications:**

Tension, alloy steel load cell.  
Mainly used for hopper scale, hanging scales and industrial weighing system.

**量程/Rated Load: 100, 200, 300, 500, 700, 1000 kg**

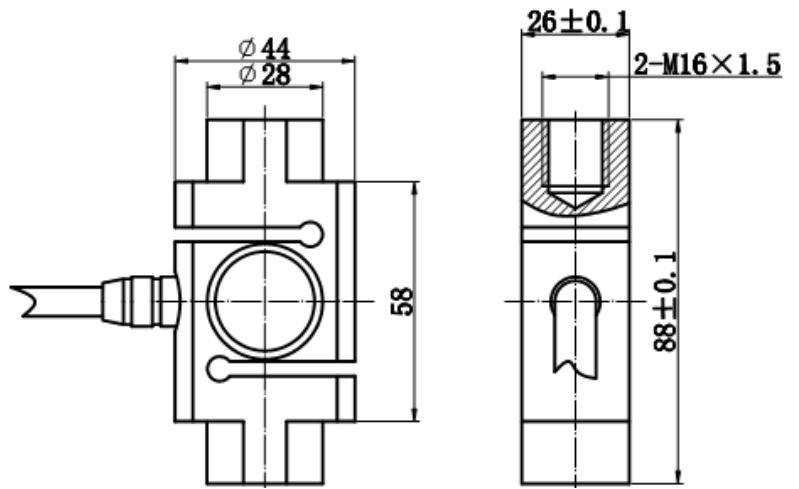
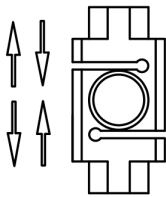

主要技术参数(specification)

输出灵敏度(Rated output)	2.0 ± 1% mV / V	绝缘电阻(Insulation)	≥5000MΩ /100VDC
零点输出(Zero balance)	± 1 % F.S.	使用电压 (Recommended excitation)	10V
非线性(Non-linearity)	0.03 % F.S.	最大使用电压 (Maximum excitation)	15 V
滞后(Hysteresis)	0.03 % F.S.	温度补偿范围 (Compensated temperature range)	- 10 ~ 40 °C
重复性(Repeatability)	0.03 % F.S.	工作温度范围 (Operation temperature range)	- 20 ~ 60°C
蠕变 (30分钟) Creep(30min)	0.03 % F.S.	安全超载(Safe overload)	150% F.S.
温度灵敏度漂移 (Temperature effect on output)	0.03 % F.S. / 10°C	极限超载(Ultimate overload)	200 % F.S.
零点温度漂移 (Temperature effect on zero)	0.03 % F.S. / 10°C	电缆线尺寸(Cable size)	Ø5 × 6000 mm
输入电阻(Input impedance)	385 ± 10 Ω	防护等级 (Protection Class)	IP65
输出电阻(Output impedance)	350 ± 4 Ω		
连接方式Cable Color Code		Input: Red(+) Black(-); Output: Green(+) White(-); 输入: 红 (+) 黑 (-); 输出: 绿 (+) 白 (-)	