

LH120

特点和用途:

单点式平行梁结构铝合金制称重传感器。主要用于电子秤、台秤、电子天平等。

Features & Applications:

Single-ended, parallel beam, aluminum load cell.

Mainly used for electronic scale, platform scale, and balance.

量程/Capacity : 5, 7, 10, 15, 20, 30 kg

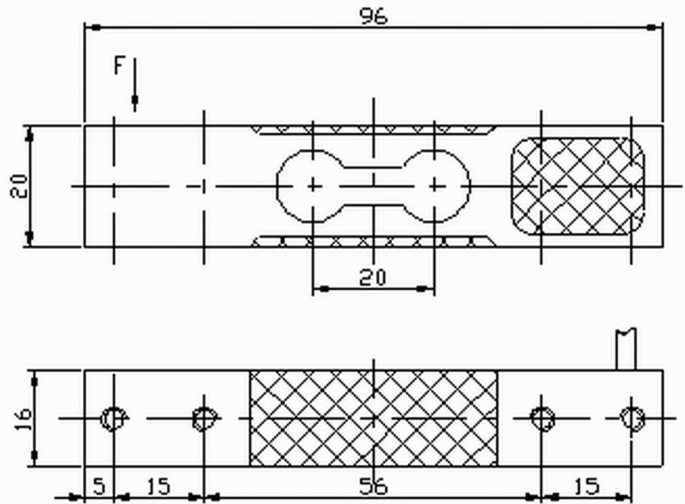
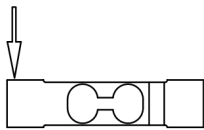
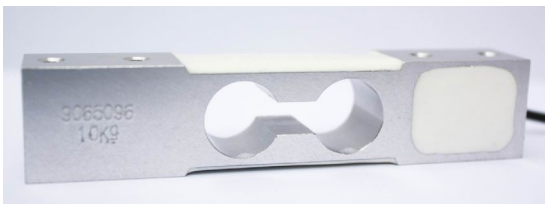

主要技术参数(Specification)			
输出灵敏度(Rated output)	2.0 ± 10% mV / V	绝缘电阻(Insulation)	≥5000MΩ /100VDC
零点输出(Zero balance)	± 2 % F.S.	使用电压 (Recommended excitation)	10V
非线性(Non-linearity)	0.02 % F.S.	最大使用电压 (Maximum excitation)	15 V
滞后(Hysteresis)	0.02 % F.S.	温度补偿范围 (Compensated temperature range)	- 10 ~ 40 °C
重复性(Repeatability)	0.02 % F.S.	工作温度范围 (Operation temperature range)	- 20 ~ 60°C
蠕变 (30分钟) Creep(30min)	0.03 % F.S.	安全超载(Safe overload)	150% F.S.
温度灵敏度漂移 (Temperature effect on output)	0.025 % F.S. / 10°C	极限超载(Ultimate overload)	300 % F.S.
零点温度漂移 (Temperature effect on zero)	0.025 % F.S. / 10°C	电缆线尺寸(Cable size)	AWG 26 × 450mm
输入电阻(Input impedance)	410 ± 10 Ω	台面尺寸(Platform size)	200 × 300 mm
输出电阻(Output impedance)	350 ± 3 Ω	防护等级 (Protection Class)	IP65
连接方式Cable Color Code		Input: Red(+) Black(-); Output: Green(+) White(-); 输入: 红 (+) 黑 (-); 输出: 绿 (+) 白 (-)	